



**GOLDBERG BROTHERS INSTALLATION GUIDE**  
**Barnfold® medium duty TOP MOUNT**  
**1 1/4" to 1 3/8" folding barn door hardware**

**hardware sets 6007M2DTM**  
 For 1 1/4" to 1 3/8" thick doors up to 24"x84"  
 with a total weight up to 125 lb.

**INCLUDED HARDWARE:**

- |                       |                            |                             |                        |                             |
|-----------------------|----------------------------|-----------------------------|------------------------|-----------------------------|
| Pre-punched track (1) | Nylon fender washers (3)   | 3/4" hex bolt (1)           | Door bottom plate (1)  | Rubber bumper band (1)      |
| Track stops (2)       | Fixed top-mount hanger (1) | 3/8" spacer (1)             | Aviation nut (1)       | 4" pull handle (1)          |
| 5" Hex lag bolts (3)  | Loose top-mount hanger (1) | Flange nuts (2)             | 3/4" steel washer (1)  | 1 3/4" Carriage bolts (2)   |
| 1" spacers (3)        | 2 1/2" wood screws (8)     | Hinges (4)                  | 1 5/8" wood screws (4) | Keys nuts (2)               |
| 1/2" spacers (6)      | 1 1/4" hex bolt (1)        | 5/8" Hinge screws (16)      | Clear bumper pads (6)  | Hinge drilling template (1) |
|                       |                            | Sidewall pivot assembly (1) | Felt strips (1)        | Door spacing template (1)   |

**Basic installation layouts**

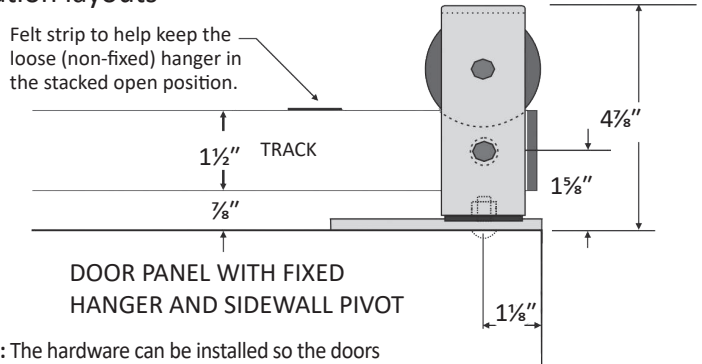
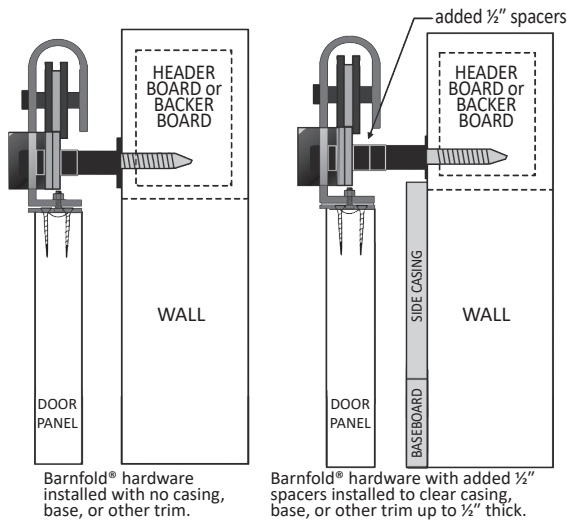

**Please note:** The hardware can be installed so the doors stack open either to the right or to the left. Illustrations throughout this document apply to doors stacking open to the right. To make the doors stack open to the left, follow the illustrations and instructions in mirror image, with all dimensions and components on the opposite sides.

**STEP 1: drill tops of both doors**

At the top of each panel on the end where a hanger will be attached, make a mark 1 5/8" in from the outer end of the panel and 5/8" in from the front of the panel.

Using a 3/4" bit, drill a hole 1/4" deep.

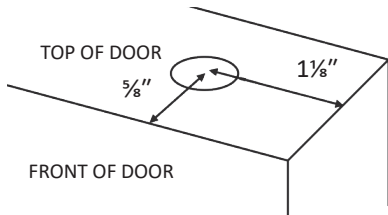

**STEP 2: drill bottom of the pivoting door panel**

At the outer bottom corner of the door panel that will pivot, make a mark 1 5/8" in from the end and 5/8" in from the front.

Using a 3/8" bit, drill a hole 1" deep.

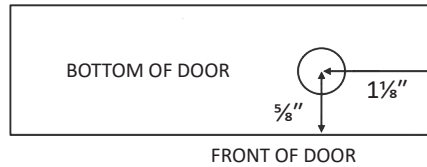

top view

**STEP 3: attach door bottom plate to the pivoting door panel**

Place the 3/4"x3" pivot plate against the outer bottom corner of the door panel that will pivot, so the non-countersunk hole in the plate aligns with the hole drilled in step 2. Attach the plate with two 1 5/8" wood screws.

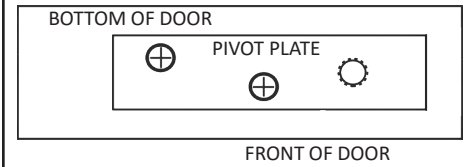

top view

**STEP 4: attach hinges to the doors**

**Important: Doors more than 7 feet tall require all four hinges. For best performance, shorter doors require only three hinges.**

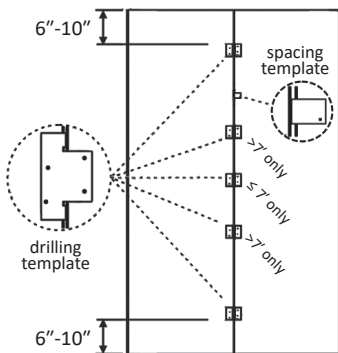

Place both door panels with the front sides down on a flat surface, with adjacent edges touching and tops and bottoms flush. Choose the three or four points where the hinges will be attached to the back of the panels. They should be approximately evenly spaced as shown. Insert the hinge drilling template between the panels at each point and insert the L-shaped door spacing template 3 to 5 feet away from the drilling template. Push both panels snugly against the two templates to keep them parallel. With a 1/8" bit, drill four pilot holes. Attach each hinge with four 5/8" hinge screws.

**STEP 5: attach the hangers**

At the upper front corners of the door panels where the two hangers will be attached, position a hanger with the mounting plate flush against the back edge and end of the door. The upside down bolt on each hanger fits in the hole drilled in step 1.

The hanger with a hole below the roller goes on the pivoting door panel. The hanger without a hole below the roller goes on the loose (non-pivoting) door panel.

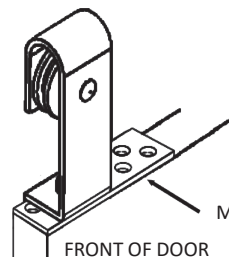
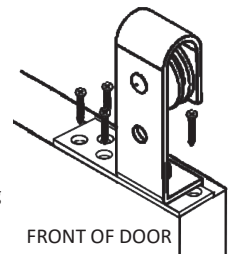

The mounting plate can be swiveled for use on either the right or left corner of the door panel.

Attach each hanger with four 2 1/4" wood screws.

Swivel tension can be adjusted. See the note on step 12.

### STEP 6: attach pull handle

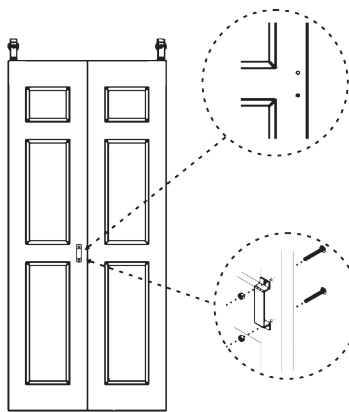

For best performance, the 4" pull handle should be installed on the door panel with the loose (non-pivoting) hanger, with the vertical center about 35" from the bottom of the panel.

Using the pull handle as a template, mark the two attachment points as shown. With a 1/8" bit, drill pilot holes through the door panel at each point. Then use a 3/4" bit to enlarge the pilot holes.

Attach the handle using the 1 1/4" carriage bolts and keps nuts as shown.

### STEP 7: mark track centerline

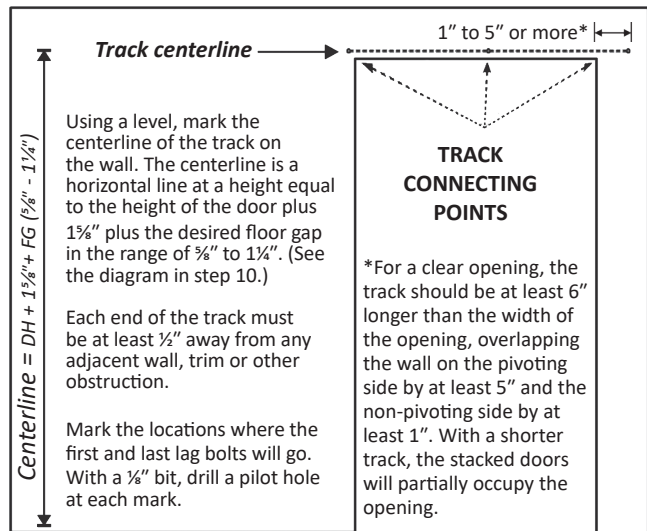

### STEP 8: attach track

Using a 5" hex lag bolt, one to three spacers†, and a fender washer, attach one end of the track to the wall.

Swing the other end of the track into position and attach it to the wall. Mark and drill a pilot hole and repeat the process for the round hole at the center of the track. A very short track may not have a center hole.

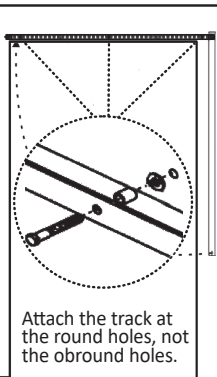

†Different combinations of spacers can be used to mount the track at various distances from the wall or header. See the side views of basic installation layouts on page 1.

### STEP 9: attach track stop and rubber bumper band

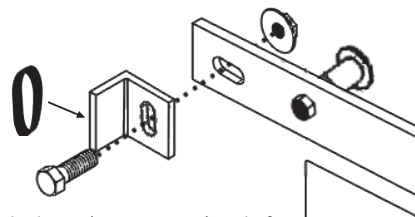

On the loose (non-pivoting) end of the track, attach a track stop with the 1" hex bolt and a flange nut as shown. Hand tighten for now, so it can be adjusted in step 14.

Attach the rubber bumper band around the track stop where it will make contact with a hanger when the doors are closed.

### STEP 10: install sidewall pivot

Screw the aviation nut on to the pivot so that the top of the nut is slightly closer to the floor than the desired floor gap (see step 8.) It will be further adjusted in step 14. Place the pivot washer over the pivot and on the aviation nut. Using two 1 1/2" wood screws, attach the sidewall pivot at the base of the wall as shown. The pivot pin should align directly below the center of the obround hole near the end of the track.

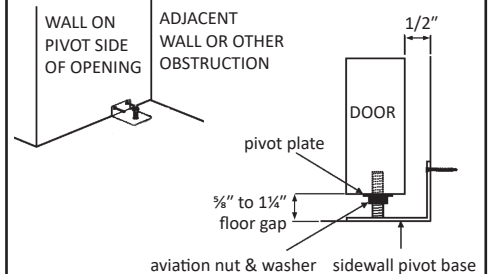

### STEP 11: hang doors on track

With an assistant, lift the assembled doors and position them so that the rollers are aligned with the track and the hole in the pivot plate is above the pivot pin.

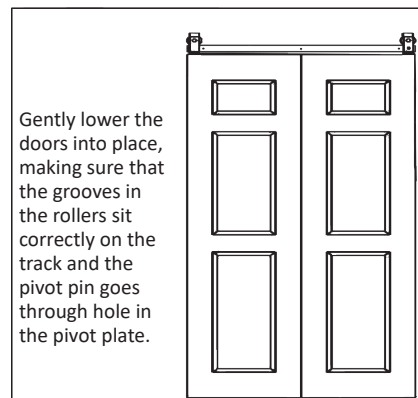

### STEP 12: attach fixed hanger stop

Attach the fixed hanger to the track using the 1 1/4" hex bolt, the 3/8" spacer, a track stop, and a flange nut. Hand tighten for now.

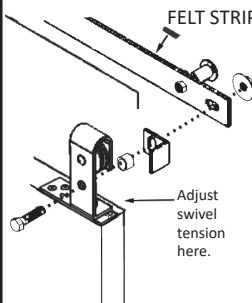

Fold open the doors so they are stacked on the pivoting side of the opening. Attach an adhesive-backed felt strip to the top edge of the track as close as possible to the bottom of the loose hanger's roller. It will create a slight bump that will help the loose hanger stay in that position.

Note: The swivel tension in either hanger can be adjusted by slightly turning the nut directly below each roller on the L-shaped base. Lighter-weight doors may need less tension than the factory setting.

### STEP 13: attach clear bumper pads & make final adjustments

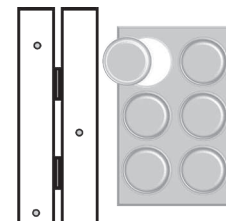

Fold the doors to access the hinged edges. Attach the 6 adhesive-backed clear bumper pads, evenly spaced along one or both inner door edges. They provide tension to help keep the doors closed.

With a wrench, turn the aviation nut on the sidewall pivot (see step 11) so that the nut and washer are firmly against the pivot plate and the bottom of the door is high enough to clear any carpet or other floor obstruction.

Further adjust and tighten the two track stops so that they apply enough pressure to the door assembly to keep it closed. The obround holes in the stops and track allow for a wide range of adjustment.

Goldberg Brothers barn door hardware products are protected against manufacturing defects with a limited lifetime warranty. See our website for details and restrictions.

goldbergbrothers.com



**GOLDBERG BROTHERS, INC.**  
10488 W. Centennial Rd., suite 100  
Littleton, CO 80128  
(303)321-1099  
reelservice@goldbergbrothers.com