



Barnfold® HD 4-door alignment and connecting plates

INCLUDED HARDWARE: 4-door alignment plates set (2 pieces)
1½" Wood screws (4)
Track connecting plate (0 or 1)*

* Hardware sets with tracks more than 96" long include two half-length track segments and one track connecting plate.

Installation of a 4-door configuration is nearly the same as installing two 2-door hardware sets end-to-end, with the fixed hangers on the two outer door panels and the rolling hangers on the two middle door panels.

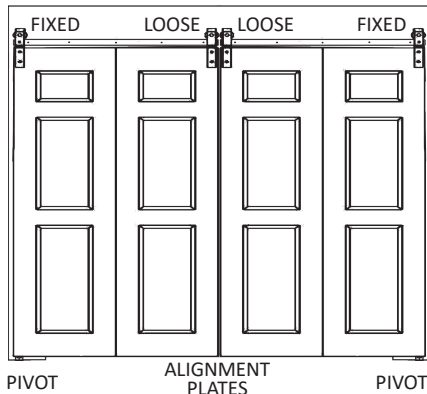

For a clear opening, the track should be at least 10" longer than the width of the opening, overlapping the wall on each side by at least 5". With a shorter track, the stacked doors will partially occupy the opening on one or both sides.



If the track is full-length, with four obround holes, follow the instructions on the installation guide for the included 2-door hardware sets. Repeat each step in mirror image, so that the fixed hangers and pivots are at the ends of the track and the loose hangers are near the middle of the track. Between steps 3 and 4 on the installation guide, follow step 3.5 on this page.



If the track consists of two half-length segments, each with two obround holes, follow the instructions on the installation guide for the included 2-door hardware sets with the following changes: between steps 3 and 4, follow step 3.5 on this page, and between steps 7 and 8, follow step 7.5 on this page. Also, skip step 10.

STEP 3.5: attach the 4-door alignment plates

Arrange the two middle door panels edge-to-edge and flush at the top and bottom. They can be touching, or have a gap of up to ⅛". With four 1½" wood screws, attach one of the two alignment plates to the bottom of each of the middle door panels as shown.

The plates should be centered front-to-back on the door panels. For added strength, they can be mortised into the door panels.

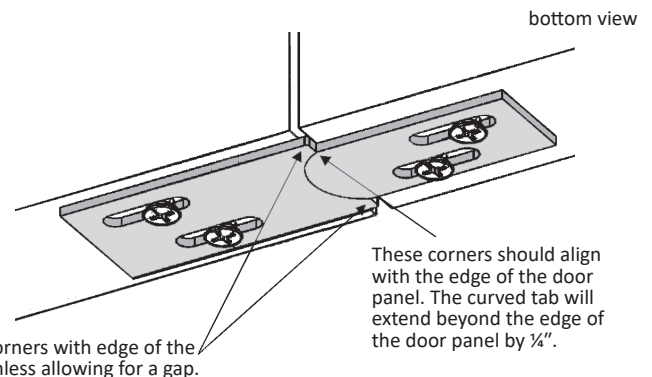

STEP 7.5: join the two half-length track segments with the track connecting plate (if applicable)

Wrap a rubber bumper band around each of two track stops on the face that does not have a hole, as shown.

Arrange the two track segments end-to-end. Join them with two 1" hex bolts, two track stops, the track connecting plate, and two flange nuts as shown. Firmly tighten the bolts for now. The bolts may be loosened to adjust the track stops in step 14 on the 2-door installation guide.

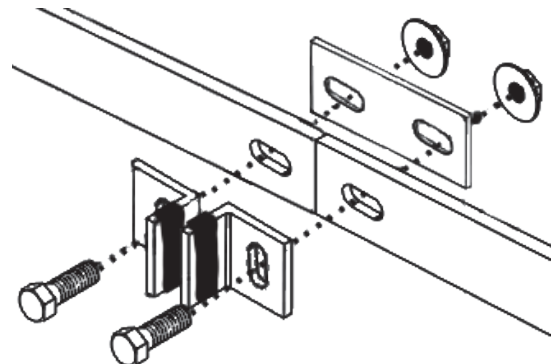

Goldberg Brothers barn door hardware products are protected against manufacturing defects with a limited lifetime warranty.

<https://goldbergbrothers.com/warranty/>



GOLDBERG BROTHERS, INC.
10488 W. Centennial Rd., suite 100
Littleton, CO 80128
(303)321-1099