

Goldberg Brothers

Soft Stop - Standard and MP Series

Step 1 - Slide the door out of the way. Completely remove the lag bolt near the end of the track. Catch the fender washer, spacer(s), and track stop as the lag bolt comes out. Reinstall the lag bolt and the other parts as before, but with the corresponding hole at the end of the Soft Stop mounting plate placed between the back of the track and the (first) spacer. The mounting plate should go flat against the track, with the device facing toward the wall. Tighten the lag bolt just enough to hold everything in place.

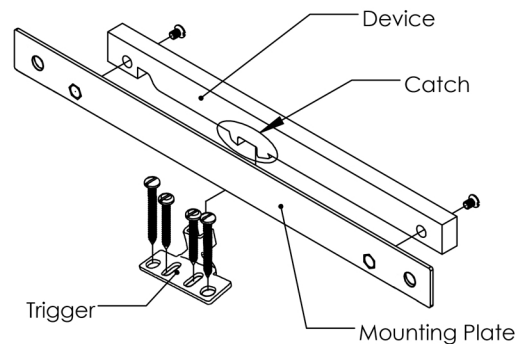

NOTE: Instructions apply to all standard 11 inch and 17 inch Soft Stop systems. Custom hole patterns over 11 inches can be made available upon request

Step 2 - Repeat the process for the second lag bolt, swinging the Soft Stop bracket into position between the track and (first) spacer. Firmly tighten both lag bolts.

Step 3 - Loosely attach the trigger to the door with two pan head screws through the center holes. If necessary, slide forward or backward to correct position. Firmly attach two flat head screws through the outer holes. Tighten all four screws.

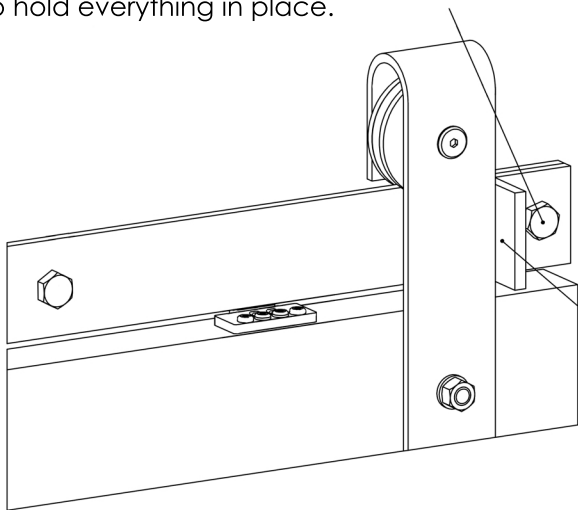

Before installing trigger, clamp hanger against stop to ensure proper alignment when door is in the open or closed position

Catch should be positioned as shown for proper trigger installation

For proper operation, device should be installed with the bottom groove sitting closest to the center of the track

Mounting plate should sit flush against the backside of the track, between the track and spacers

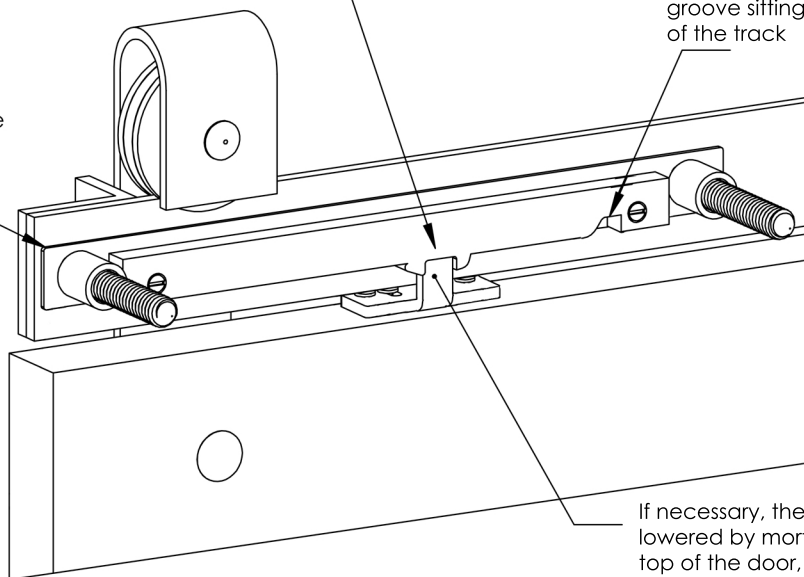

Trigger should be installed so that it sits between the "teeth" of the catch on the device

If necessary, the trigger can be lowered by mortising it into the top of the door, to ensure that the trigger fits properly without hitting or scraping the device

These installation instructions apply to Soft Stop kits with round lag bolt mounting holes manufactured after August 1, 2023.

GOLDBERG BROTHERS, INC.

GoldbergBrothers.com